

TS-850S

ADJUSTMENT

Required Test Equipment

1. DC Voltmeter (DC V.M)

- 1) Input resistance : More than 1M Ω
- 2) Voltage range : 1.5 to 1000V AC/DC

Note : A high-precision multimeter may be used. However, accurate readings can not be obtained for high-impedance circuits.

2. DC Ammeter

- 1) Current range : 100mA, 1.5A, 15A, High-precision ammeter may be used.

3. RF VTVM (RF V.M)

- 1) Input impedance : 1M Ω and less than 3pF, min.
- 2) Voltage range : 10mV to 300V
- 3) Frequency range : 10kHz to 500MHz

4. AF Voltmeter (AF V.M)

- 1) Frequency range : 50Hz to 10kHz
- 2) Input resistance : 1M Ω or greater
- 3) Voltage range : 10mV to 30V

5. AF Generator (AG)

- 1) Frequency range : 200Hz to 5kHz
- 2) Output : 1mV or less to 1V, low distortion

6. AF Dummy Load

- 1) Impedance : 8 Ω
- 2) Dissipation : 3W or greater

7. Oscilloscope

Requires high sensitivity, and external synchronization capability (150MHz or greater).

8. Sweep Generator

- 1) Center frequency : 50kHz to 90MHz
- 2) Frequency deviation : Maximum ± 35 MHz
- 3) Output voltage : 0.1V or greater
- 4) Sweep rate : At least 0.5 sec/cm

9. Standard Signal Generator (SSG)

- 1) Frequency range : 50kHz to 50MHz
- 2) Output : -20dB/0.1 μ V to 120dB/1V
- 3) Output impedance : 50 Ω
- 4) AM and FM modulation can be possible.

Note : Generator must be frequency stable.

10. Frequency Counter (f. counter)

- 1) Minimum input voltage : 50mV
- 2) Frequency range : 150MHz or greater

11. Noise Generator

Must generate ignition noise containing harmonics beyond 30MHz

12. RF Dummy Load

- 1) Impedance : 150 Ω and 50 Ω
- 2) Dissipation : 150W or greater

13. Linear Detector

- 1) Frequency range : 30MHz

14. Power Meter

- 1) Impedance : 50 Ω
- 2) Dissipation : 300W continuous or greater
- 3) Frequency limits : 60MHz or greater

15. Spectrum Analyzer

- 1) Frequency range : 100kHz to 110MHz or greater
- 2) Bandwidth : 1kHz to 3MHz

16. Detector

- 1) For adjustment of BPF

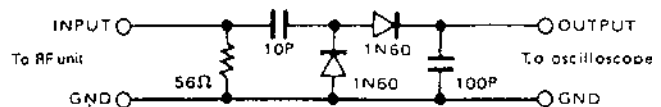

- 2) For adjustment of PLL/VCO BPF

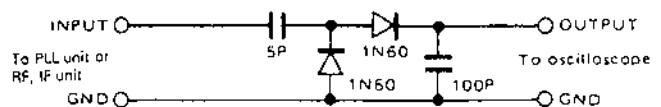

17. Directional Coupler

18. Monitor Receiver

R-1000 class

19. Microphone

MC-43S or MC-60/60S8

20. Tracking Generator

Preference

Japanese "SG"	American "SG"
-6dB	0.25 μ V
0dB	0.5 μ V
6dB	1 μ V
12dB	2 μ V
24dB	8 μ V
30dB	15.8 μ V
40dB	50 μ V
50dB	158 μ V
60dB	500 μ V
70dB	1.58mV
80dB	5mV
90dB	15.8mV
100dB	50mV
120dB	0.5V

ADJUSTMENT

Preparation

• Setting

Set the mark position of round knob as drawing below.

There should not comes out easily.

Push knob are all OFF.

Front Panel

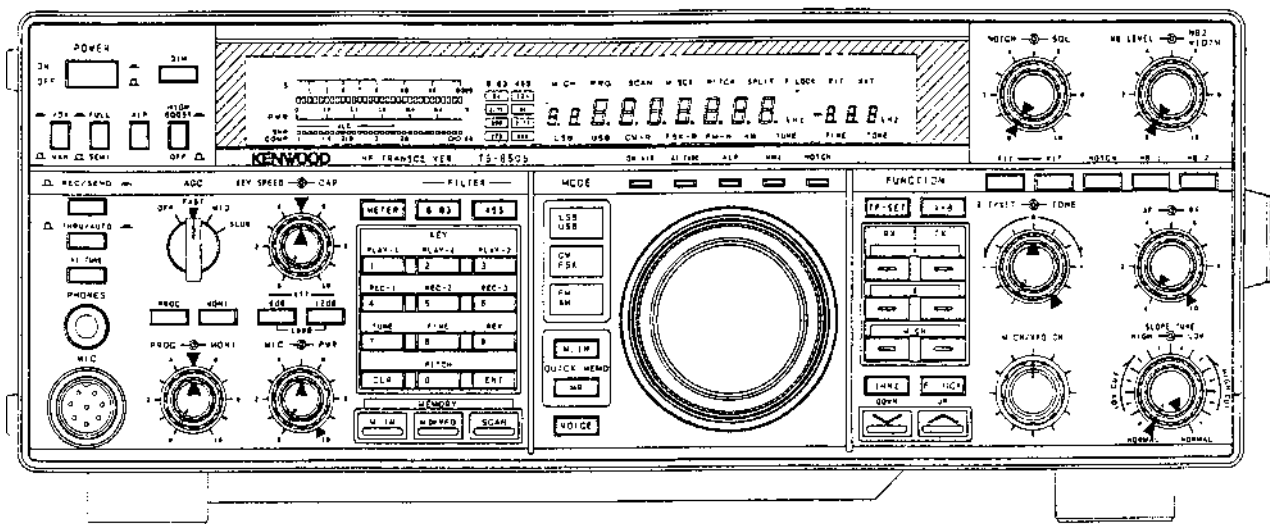

Rear Panel

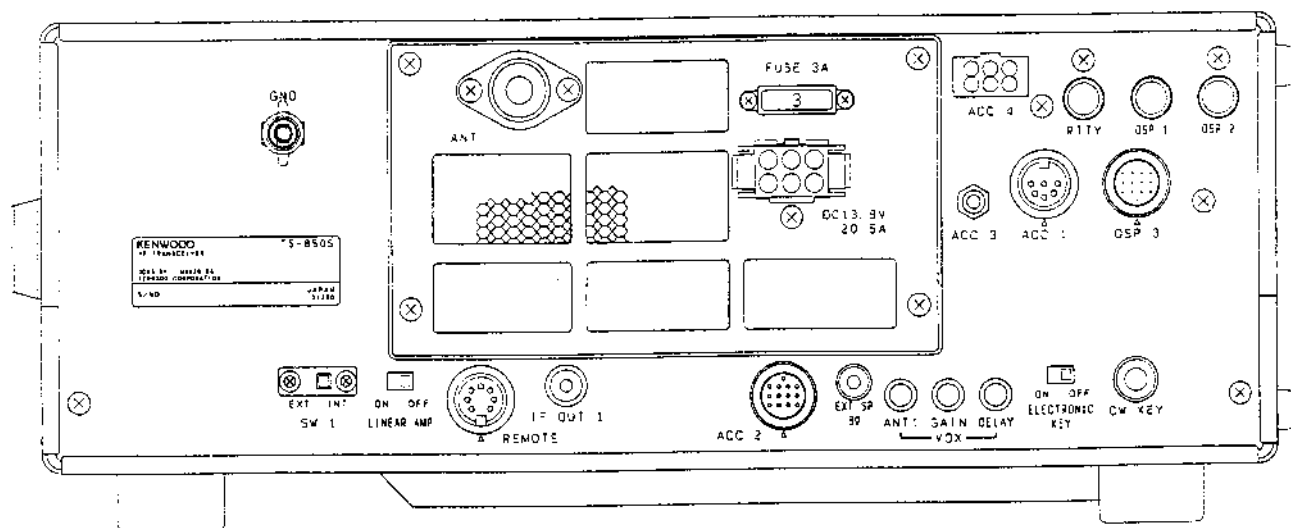

TS-850S

ADJUSTMENT

PLL Section Adjustment

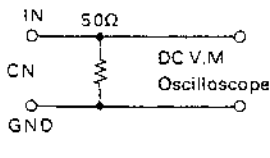
Item	Condition	Measurement			Adjustment			Specifications/Remarks	
		Test-equipment	Unit	Terminal	Unit	Parts	Method		
1. 20MHz frequency	1) POWER : ON MODE : FM STBY : REC	f. counter	CAR	TP1	PLL	TC5	20,000,000Hz ADJ.	20MHz ± 20Hz	
2. L34,35 adjustment	1) MODE : FM STBY : REC	RF V.M	PLL	IC1 pin 2	PLL	L34,35	Level MAX		
3-1. L19,20,21 adjustment	1) Display f. : 14.250MHz MODE : FM STBY : REC	RF V.M	PLL	TP4	PLL	L19,20 L21	Level MAX		
3-2. TP4 frequency	2) Display f. : 14.250MHz	f. counter					Check	55.299-55.301MHz	
4. VCO1 adjustment	1) Display f. : 30kHz	DC V.M	PLL	TP1	PLL	TC1	2.3V	2.3 ± 0.03V	
4-1. VCO1 level check	2) Display f. : 7.499MHz					Check		6.0-8.0V	
5. VCO2 adjustment	1) Display f. : 7.500MHz	DC V.M	PLL	TP1	PLL	TC2	2.3V	2.3 ± 0.03V	
5-1. VCO2 level check	2) Display f. : 14.499MHz					Check		6.0-8.0V	
6. VCO3 adjustment	1) Display f. : 14.500MHz	DC V.M	PLL	TP1	PLL	TC3	2.3V	2.3 ± 0.03V	
6-1. VCO3 level check	2) Display f. : 21.499MHz					Check		6.0-8.0V	
7. VCO4 adjustment	1) Display f. : 21.500MHz	DC V.M	PLL	TP1	PLL	TC4	2.3V	2.3 ± 0.03V	
7-1. VCO4 level check	2) Display f. : 30.000MHz					Check		6.0-8.0V	
8. LO2 VCO adjustment (X58-3390-03)	1) Display f. : 30.000MHz	DC V.M	PLL	TP2	VCO2 (X58-3390)	TC1	5.0V	5.0 ± 0.03V	
9. Level check LO1 (CN5) LO2 (CN6) 20MHz (CN2) 10kHz (CN9)	1) Display f. : 14.250MHz MODE : FM STBY : REC 	DC V.M	PLL	CN5			Check	-5--+2dBm	
					CN6			Check	-1--+6dBm (64.220MHz)
					CN2			Check	-10--+0dBm (20.000MHz)
					CN9			Check	500-1000mVp-p (10.0kHz)
10. 20MHz frequency	1) MODE : FM STBY : REC	f. counter	CAR	TP1	PLL	TC5	20,000,000Hz ADJ.	20MHz ± 5Hz	

ADJUSTMENT

Receiver and Transmitter Section Adjustment

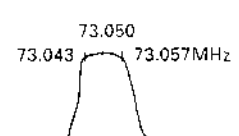
Item	Condition	Measurement			Adjustment			Specifications/Remarks
		Test-equipment	Unit	Terminal	Unit	Parts	Method	
1. Display check and reset	1) DC IN : 13.8V Connect the DC plug POWER : ON After checked POWER : OFF Pushing A=B, POWER : ON				Display		Reset display Display f. : 14.000.00kHz MODE : USB FUNCTION RX : A FUNCTION TX : A METER : ALC FILTER 8.83 : 2.7K FILTER 455 : 2.7K	Must display correctly. Must be no generation of smoke or abnormal noise. Should be at the reset frequency.
2. Reference oscillation		f. counter	CAR	TP1	PLL	TC5	20.000.000Hz ADJ.	±20Hz
3. Slope tune, RIT/XIT	1) POWER : OFF Pushing F. LOCK key down POWER : ON SLOPE TUNE HI/LOW : Left turn MAX Turn the click encoder (M.CH) and set the display to 03 (MENU No. 3) HI/LOW VR : After concluded right turn HI MAX	DISP			SW A (A/6)	VR4	Set the display to 0.	±1
	2) Display : 04 (MENU No. 4) After adjusted SLOPE TUNE HI : Normal (right turn MAX)					VR5	Set the display to 0.	±1
	3) RIX/XIT VR : Mechanical center Display : 02 (MENU No. 2) CLR key : Push					VR3	Set the display to 0. 0	0
4. AGC	1) POWER : OFF to ON Display f. : 14.000MHz MODE : USB RF GAIN : MAX	DC V.M	RF	TP1	IF	VR15	2.8V ADJ.	±0.01V
	2) MODE : FM					VR14	2.8V ADJ.	±0.01V
5. ALC voltage	1) Remove RF unit CN2. MODE : USB Display f. : 14.200MHz PWR : MAX STBY : SEND	DC V.M	RF	TP3	RF	VR14	2.7V	±0.05V
6. MCF	1) Tracking generator output : -10dBm Center f. : 73.050MHz AGC : OFF	Spectrum analyzer Tracking generator	RF	TP2 (CN6) TP1 (CN5)	RF	L59- L62	Repeat 2~3 times. Adjust so that gain is max. and band shown at right becomes flat.	

TS-850S

ADJUSTMENT

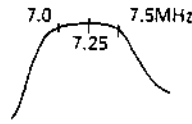
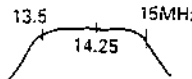
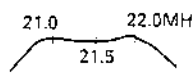
Item	Condition	Measurement			Adjustment			Specifications/Remarks
		Test-equipment	Unit	Terminal	Unit	Parts	Method	
7. SPF	1) ENT 7 ENT key : Push Display f. : 7.000MHz MODE : Arbitrary AIP : OFF Tracking generator output : -20dBm	Spectrum analyzer Tracking generator	RF Rear panel	TP4 (CN27) ANT	RF	L19-L21		
	L28-L30							
	L34-L36							
8-1. IF AMP (1)	1) Display f. : 14.2MHz MODE : CW CAR : 10 o'clock Connect test instrument to IF unit CN6. Spectrum analyzer SPAN : 50kHz ST : 305ms RBW : 1kHz STBY : SEND	50Ω load RF V.M or Synchro scope or Spectrum analyzer	RF	CN2	IF	L5-L7	Set 14.2MHz signal to MAX.	
8-2. IF AMP (2)	2) MODE : CW CAR : MAX Connect test instrument to RF unit CN2. STBY : SEND					RF	L77,79 L80,82 L83,84 L87 VR2	Set 14.2MHz signal to MAX.
9. MIX balance	1) ENT 249 ENT key : Push Display f. : 24.900MHz STBY : SEND After adjusted connect CN2.	Spectrum analyzer	RF	CN2	RF	VR3	±1.65MHz Spurious : MIN	-70dBm or less with respect to 24.9MHz and 10dBm.
10. MIX BAL	1) ENT 001 ENT key : Push Display f. : 0.100MHz MODE : LSB AF VR : MAX SLOPE TUNE HI : Fully CW position LOW : Fully CCW position TONE : Fully CW position After adjusted AF VR : MIN	AF V.M DM. SP	Rear panel	EXT. SP	RF	VR1	Adjust noise level to minimum level. Although noise will be produced when the VR is turning, this is not malfunction.	1kHz ± 100Hz
11. RF. IF AMP	1) ENT 141 ENT key : Push Display f. : 14.100MHz MODE : USB AGC : OFF AIP : OFF AF VR : 0.63V/8Ω SSG f. : 14.101MHz SSG ATT : -6dBμ Make adjustments at as low as input level as possible.	SSG DM. SP Oscilloscope AF V.M	Rear panel	ANT EXT. SP	RF	L56,81 L67,68 L69,70	Repeat 2 times for MAX AF output reading.	
						IF		
	2) FILTER 8.83 SW : Set to the position where the display disappears. After adjusted Return to 2.7kHz SUB : OFF				RF	L74,75	MAX for AF output.	

ADJUSTMENT

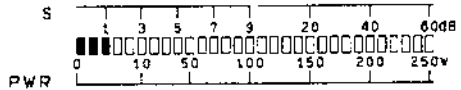
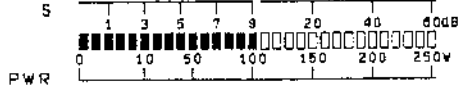
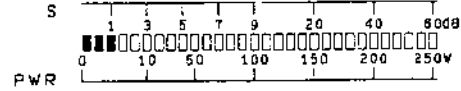
Item	Condition	Measurement			Adjustment			Specifications/Remarks
		Test-equipment	Unit	Terminal	Unit	Parts	Method	
12. IF OUT 1	1) SSG ATT : 90dB μ AF VR : MIN	SSG Synchro scope	Rear panel	ANT IF OUT 1	RF	L64,65	Adjust 8.83MHz signal to MAX level.	
13. S-meter adjustment and RX GAIN check	1) Display f. : 14.100MHz MODE : USB AGC : OFF RF GAIN : MAX SSG RF : OFF	DC V.M	IF	TP2	IF	VR12	0.1V	$\pm 0.01V$
	2) AGC : FAST SSG ATT : 6dB μ					VR13	MAX	
						L17	S1 (After 3 dots lights)	
	3) SSG ATT : 32dB μ					VR13	S9 (After S9 lights)	
	4) SSG ATT : 6dB μ					VR17	S1	
	5) SSG ATT : 32dB μ					Check	Within S9 +4, -8dB μ	
6) SSG ATT : 6dB μ	Check	S1 lit, $\pm 3dB\mu$						
14. ATT check	1) Display f. : 14.100MHz AGC : OFF SSG : 6dB μ AF VR : 1V/8 Ω	SSG DM. SP Oscilloscope AF V.M	Rear panel	ANT EXT. SP	Front panel	ATT SW 0dB 6dB 12dB 18dB	Check AF output should be lowered 6dB at time.	SSG ATT : Within $\pm 3dB$ ATT SW 0dB \rightarrow 1V (0dB) 6dB \rightarrow 0.5V (-6dB) 12dB \rightarrow 0.25V (-12dB) 18dB \rightarrow 0.15V (-18dB)
15. FM GAIN	1) ENT 2B2 ENT key : Push Display f. : 28.200MHz MODE : FM SSG f. : 28.200MHz MOD : 1kHz DEV : 3kHz ATT : 20dB μ				IF	L21	AF output MAX.	
16. FM S-meter	1) SSG ATT : 30dB μ				IF	VR10	Set the S-meter to just before 60 dots lights.	

TS-850S

ADJUSTMENT

Item	Condition	Measurement			Adjustment			Specifications/Remarks	
		Test-equipment	Unit	Terminal	Unit	Parts	Method		
17. NB	1) SSG ATT : 6dB μ	SSG DC V.M	Rear panel	ANT	RF (B/4)	L602 L603	TP600 output MIN		
	2) ENT 212 ENT key : Push Display f. : 21.200MHz MODE : USB AGC : FAST AF VR : Arbitrary NB1 : ON NB LEVEL : 12 o'clock	Noise generator Speaker		ANT EXT. SP				Adjust output of noise generator to small input (S1) and large input (S9) and check each.	Noise should disappear.
	3) NB2 WIDTH : MIN NB2 : ON After adjusted NB1 and NB2 : OFF						Check	When output SW of noise generator is set to NB2 and TIME VR is turned all the way to the right and left, noise should disappear by varying the set NB2 WIDTH.	
18. Beep tone adjustment	1) AF VR : MIN CW/FSK key : 1 push	DM. SP Oscilloscope	Rear panel	EXT. SP	IF	VR4	0.2Vp-p	0.1-0.3Vp-p	
19. Voice check (equipped on VS-2)	1) AF VR : Arbitrary						Check	When the VOICE key on the front panel pushed once, the displayed frequency can be heard vocally.	
20. S/N check	1) Display f. : Indicated below AF VR : 1.0V/8 Ω SSG f. : Indicated below However, USB : +1kHz LSB : -1kHz								Note : As AIP will be turned on automatically at frequencies of 9.5kHz or less, turn it off with the AIP SW.
	Frequency (M. CH)	MODE	SG ATT	SG MOD	DEV				
	100kHz	AM	14dB μ	1kHz	30%			S/N measurement	10dB or more
	1.500MHz	AM	36dB μ					MAX sensitivity measurement	0.7V/8 Ω or more
	1.800MHz	LSB	-6dB μ	OFF					
	3.500MHz	LSB	-6dB μ	OFF					
	5.500MHz	LSB	-6dB μ	OFF					
	7.100MHz	LSB	-6dB μ	OFF					
	10.100MHz	USB	-6dB μ	OFF					
	12.500MHz	USB	-6dB μ	OFF					
	14.100MHz	USB	-6dB μ	OFF					
	18.100MHz	USB	-6dB μ	OFF					
	21.100MHz	USB	-6dB μ	OFF					
	24.800MHz	USB	-8dB	OFF					
29.800MHz	USB	-8dB	OFF						
29.800MHz	FM	-6dB μ	1kHz	3kHz			SINAD sensitivity measurement	12dB SINAD or more	

ADJUSTMENT

Item	Condition	Measurement			Adjustment			Specifications/Remarks	
		Test-equipment	Unit	Terminal	Unit	Parts	Method		
21. SSB squelch	1) ENT 141 ENT key : Push Display f. : 14.100MHz MODE : USB AGC : SLOW SSG f. : 14.101MHz SSG RF : OFF SQL VR : 12 o'clock	SSG DM. SP Oscilloscope AF V.M	Rear panel	ANT EXT. SP	IF	VR11	Set to the point squelch closes.		
	2) SSG ATT : 12dB μ						Check		Squelch should open.
	3) SQL VR : MAX SSG ATT : 30dB μ								Squelch should open.
22. FM squelch	1) ENT298 ENT key : Push Display f. : 29.800MHz MODE : FM SSG RF : OFF	SSG DM. SP Oscilloscope AF V.M	Rear panel	ANT EXT. SP			Adjust SQL VR is slowly increase noise just goes off.	Knob position 8 : 00 - 12 : 00	
	2) SSG ATT : -6dB μ MOD : 1kHz DEV : 3kHz						Check	Squelch should open.	
	3) SQL VR : MAX SSG ATT : 13dB μ After adjusted SQL VR : MIN							Squelch should open.	
23. Base current	1) Display f. : 14.1750MHz MODE : USB MIC VR : MIN CAR VR : MIN Final unit VR1, VR2 : MIN Connect ammeter + : EXT. power supply - : Power connector Adjust to minimum current with VR1 and VR2 in the final unit. STBY : SEND	Ammeter			Final	VR1	Current drain (Minimum current) + 200mA	First: adjust VR1 and VR2 for minimum. Adjust VR1 for an increase of 200mA when switched to TX. Then adjust VR2 for 200mA over this reading.	
						VR2	Current drain (Minimum current) + driver current (200mA) + 200mA.		
24. NULL	1) ENT 035 ENT key : Push MODE : CW Display f. : 3.500MHz CAR VR : MIN RF unit VR7, VR8 : MIN STBY : SEND	DC V.M Power meter	Filter Rear panel	TP1 ANT	Filter	TC1	Turn up CAR set to 10W. Reduce the voltage to the minimum level by turning TC1.	Ref. 50mV or less	
25. ALC adjustment	1) Display f. : 14.200MHz CAR VR : MIN RF unit VR7 : MAX RF unit VR8 : MIN MODE : CW CAR VR : Turn slowly to the right starting at minimum. STBY : SEND	Power meter	Rear panel	ANT	RF	VR7	After checking that only an output of roughly 10W is generated when CAR VR is turned to MAX, adjust to 100W.	\pm 5W	

TS-850S

ADJUSTMENT

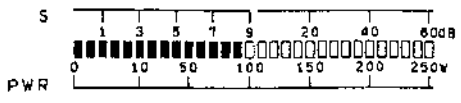
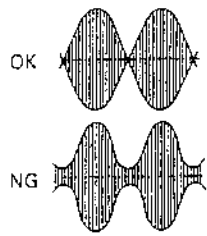
Item	Condition	Measurement			Adjustment			Specifications/Remarks
		Test-equipment	Unit	Terminal	Unit	Parts	Method	
26. ALC frequency characteristic	1) ENT 296 ENT key : Push Display f. : 29.600MHz CAR VR : MAX STBY : SEND	Power meter	Rear panel	ANT	Filter	VR1	90W	±5W
	2) ENT 142 ENT key : Push Display f. : 14.200MHz STBY : SEND						When the above range is exceeded during transmission, repeat the above adjustment.	
27. Power meter	1) PWR : MAX CAR VR : MAX STBY : SEND	Power meter	Rear panel	ANT	RF	VR9	Adjust power set to 90W. 	90W dot should go out at 88W or higher by turning PWR.
28. Power down	1) ENT 287 ENT key : Push Display f. : 28.700MHz RF unit S1 : ON PWR : MAX STBY : SEND After adjusted S1 : OFF	Power meter	Rear panel	ANT	RF	VR4	55W	±5W
	2) TUNE : ON (7 key) PWR : MAX RF unit VR6 : MAX STBY : SEND After adjusted TUNE : OFF					VR6	55W	±5W
29. MIN power	1) PWR : MIN STBY : SEND	Power meter	Rear panel	ANT	RF	VR5	10W	20W or less
30. Power control tracking	1) MODE : CW PWR : MAX STBY : SEND Turn CAR VR and set to ALC meter zone MAX.	Power meter	Rear panel	ANT	RF	TC1	Reduced PWR to MIN and adjust TC1 so that ALC meter reaches zone MAX.	
31. Carrier point	1) ENT 142 ENT key : Push Display f. : 14.200MHz While pushing the F. LOCK key, POWER : ON [Display the MENU No. of M. CH] Display : 00 (MENU No. 00) MODE : USB/LSB 8.83MHz filter key : 6kHz AG1 : 900Hz/5mV AG2 : 3500Hz/5mV MIC : Level at which not activated STBY : SEND	Power meter	Rear panel	ANT	RF (D/4)	VR501	Adjust so that waveforms cross with LSB.	OK 
		Oscilloscope	Front panel	MIC		VR502	Adjust so that waveforms cross with USB.	
	2) 8.83MHz filter key : 2.7kHz Turn the click encoder to set MENU 1. MODE : LSB/USB AG1 : 1kHz/5mV AG2 : 3.4kHz/5mV MIC : Turn slowly STBY : SEND After adjusted CLR key : Push						VR503	Adjust so that waveforms cross with USB. Check so that waveforms cross with LSB. When the waveforms do not cross with LSB, adjust while changing the mode to set to the same waveform.

ADJUSTMENT

Item	Condition	Measurement			Adjustment			Specifications/Remarks
		Test-equipment	Unit	Terminal	Unit	Parts	Method	
32. CAR suppression	1) Display f. : 14.2MHz MODE : USB/LSB MIC : MIN STBY : SEND After adjusted connect CN6.	50Ω load RF V.M or Synchro scope or Spectrum analyzer	RF	CN2	IF	VR8,9	Alternately turn the VR to set CAR to the MIN level. Should go to the minimum level when VR is turned all the way. Check both LSB and USB.	-50dB or less There is a dip point near center position of the VR.
33. PROC AMP and meter	1) PROC SW : ON PROC VR : Mechanical center position AG : 1kHz/10mV STBY : SEND	Power meter Oscilloscope AG AF V.M	Rear panel	ANT	IF	L8	MAX Adjust MIC so that it remains constantly at roughly 40W.	
	2) Meter : COMP AG : 1kHz/1mV STBY : SEND PROC VR : Until the oscilloscope waveform becomes saturated.		Front panel	MIC			Adjust PROC VR and set to roughly 80% of oscilloscope waveform saturation.	
	3) AG : 1kHz/10mV STBY : SEND After adjusted, PROC SW : OFF				RF	VR13	Adjust so that 21dB dot lights.	
	4) AG : 1kHz/1mV STBY : SEND						Check	One dot of the COMP meter should be lit.
34. ALC meter	1) Meter : ALC AG : 1kHz/5mV MODE : USB MIC VR : MIN RF unit VR12 : MAX STBY : SEND	Power meter DC V.M	Rear panel	ANT	RF	VR11	Adjust prior to voltage deviation.	0V
	2) AG : 1kHz/5mV STBY : SEND	AG AF V.M Power meter	Front panel	MIC			Adjust so that ALC meter one dot lights with MIC VR.	
	3) AG : 1kHz/10mV STBY : SEND					VR12	Adjust so that ALC meter lights to zone MAX.	
35. Spurious	1) ENT 249 ENT key : Push Display f. : 24.900MHz STBY : SEND	Spectrum analyzer	RF	CN2	RF	VR3	±1.65MHz Spurious level MIN	-60dB or less (24.9MHz)
36. SWR protection	1) MODE : CW CAR VR : MIN PWR : MAX RF unit VR8 : MAX STBY : SEND	150Ω dummy load Through-type power meter	Rear panel	ANT	RF	VR8	40W Note : Perform adjustment quickly.	±5W
			<pre> graph LR TS850[TS-850] --- 1m1[1m] --- PM((Power meter)) PM --- 1m2[1m] --- Dummy[Dummy] </pre>					
37. SWR meter	1) ENT 18 ENT key : Push Display f. : 1.800MHz Meter : SWR STBY : SEND	150Ω dummy load	Rear panel	ANT	RF	VR10	SWR : 3 Adjust just after SWR 3 dot lights.	

TS-850S

ADJUSTMENT

Item	Condition	Measurement			Adjustment		Specifications/Remarks		
		Test-equipment	Unit	Terminal	Unit	Parts		Method	
38. FM MAX DEV	1) ENT 282 ENT key : push Display f. : 28.800MHz MODE : FM CAR VR : MAX AG : 1kHz/50mV (K.P.M), 30mV (X.E) STBY : SEND	Power meter Linear detector AG AF V.M	Rear panel	ANT	RF (B/4)	VR603	±4.6kHz	±0.1kHz	
			Front panel	MIC			VR601		±3kHz
							VR602		±2.3kHz
39. FM MIC SENS	1) AG : 1kHz/5mV (K.P.M), 3mV (X.E) STBY : SEND						±1.5kHz	±0.1kHz	
40. FM NAR MAX DEV	1) 455 key : Push AG : 1kHz/50mV (K.P.M), 30mV (X.E) STBY : SEND								
	2) AG : 1kHz/5mV (K.P.M), 3mV (X.E) STBY : SEND								
41. Monitor level	1) Display f. : 21.100MHz MODE : USB MONI SW : ON MONI VR : 11 o'clock Meter : ALC MIC : AG (1kHz/10mV) MIC VR : ALC zone MAX STBY : SEND	Power meter DM. SP Oscilloscope AF V.M	Rear panel	ANT EXT. SP			Check	0.63V or more / 8Ω	
42. Side tone	1) MODE : CW AF VR : Center KEY : Down MONI SW : OFF PITCH VR : OFF VOX SW : ON Rear panel ELECTRONIC KEY : OFF LINEAR AMP : ON	DM. SP AF V.M ELE. KEY Power meter f. counter	Rear panel	EXT. SP CW KEY ANT Remote RTTY EXT. SP	IF	VR5	Adjust to 0.2V/8Ω with key down.	0.18 - 0.22V	

Adjustment Points (Side)

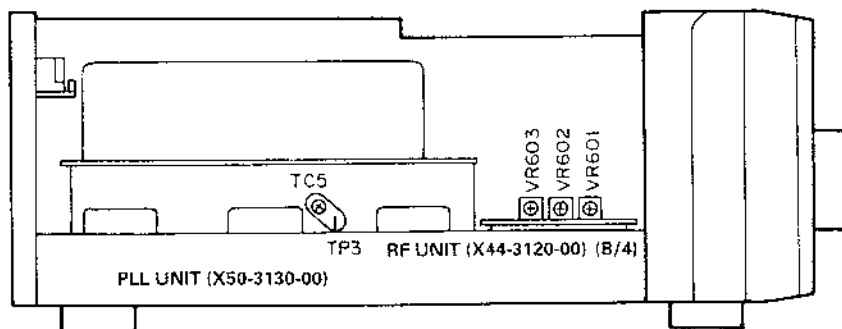

PLL UNIT (X50-3130-00)
TC5 : Ref. OSC, 20MHz frequency

RF UNIT (X44-3120-00) (B/4)
VR601 : FM MIC SENS
VR602 : FM NARROW MAX DEV
VR603 : FM MAX DEV
L602,603 : NB

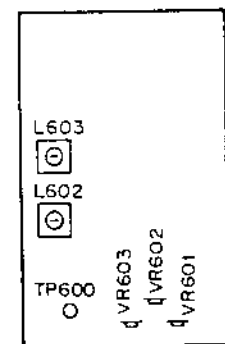

RF UNIT (X44-3120-00) (B/4)

ADJUSTMENT

Adjustment Points (Upper)

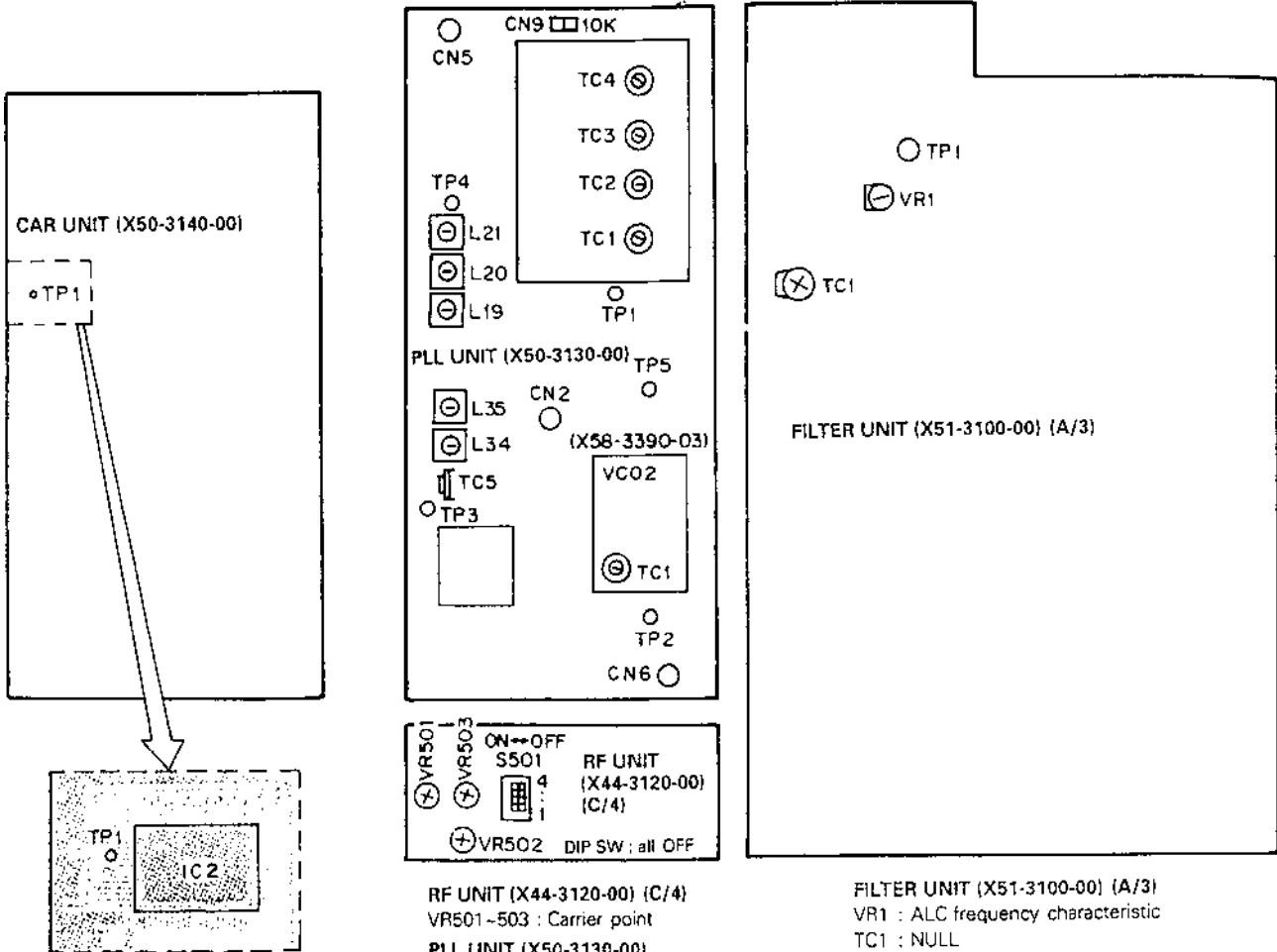

RF UNIT (X44-3120-00) (C/4)
 VR501-503 : Carrier point
PLL UNIT (X50-3130-00)
 L19-21 : Peak level
 L34,35 : Peak level
 TC1 : VCO1
 TC2 : VCO2
 TC3 : VCO3
 TC4 : VCO4

VCO2 (X58-3390-03)
 TC1 : LO2 VCO

FILTER UNIT (X51-3100-00) (A/3)
 VR1 : ALC frequency characteristic
 TC1 : NULL

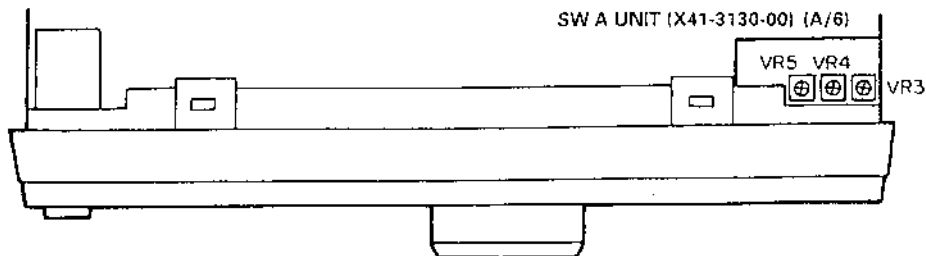

SW A UNIT (X41-3130-00) (A/6)
 VR3-5 : Slope tune and RIT/XIT

TS-850S

ADJUSTMENT

Adjustment Points (Lower)

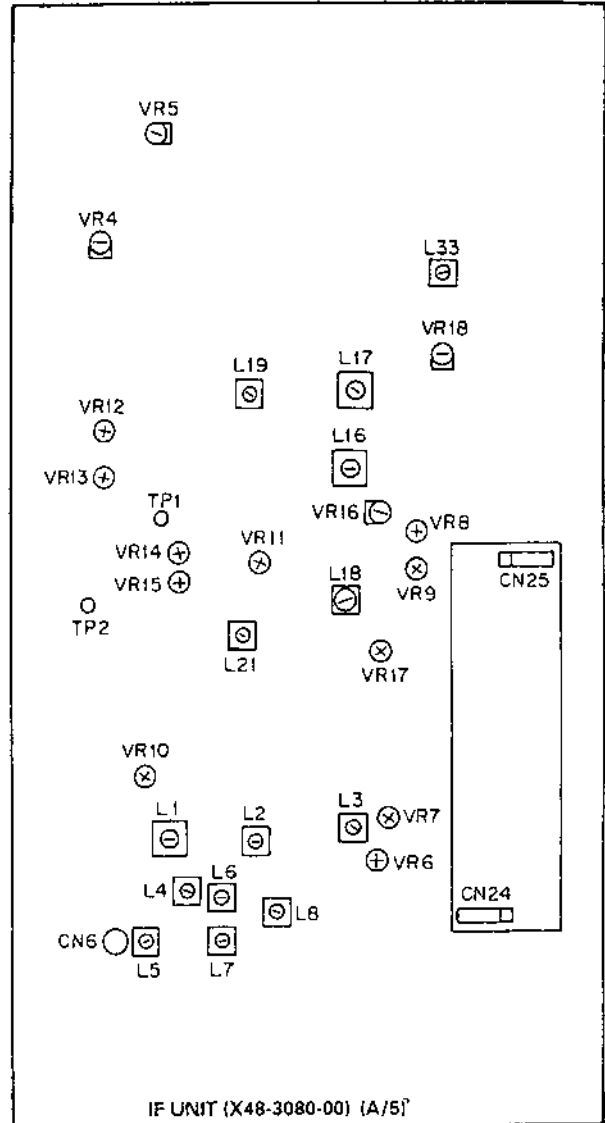
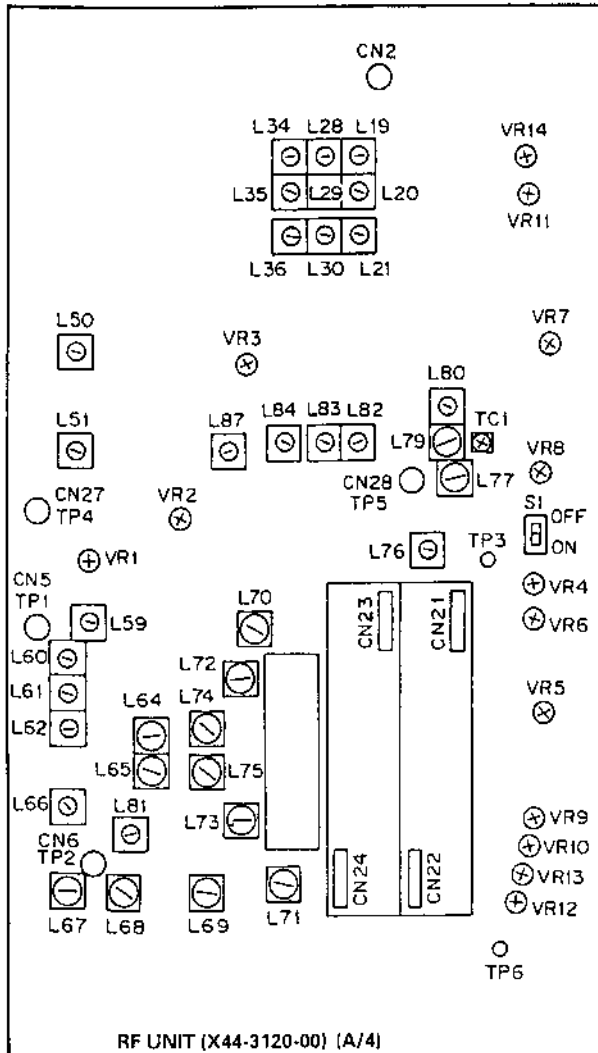

RF UNIT (X44-3120-00) (A/4)

- VR1 : MIX BAL
- VR2 : IF AMP
- VR3 : MIX balance, spurious
- VR4,6 : Power down
- VR5 : MIN power
- VR7 : ALC
- VR8 : SWR protection
- VR9 : Power meter
- VR10 : SWR meter
- VR11,12 : ALC meter
- VR13 : PROC amp and meter
- VR14 : ALC voltage
- TC1 : Power control tracking
- L19~21 : BPF (7~7.5MHz)
- L28~30 : BPF (14~14.5MHz)
- L34~36 : BPF (21~22MHz)
- L59~62 : MCF
- L64,65 : IF OUT 1
- L66~70,74,75,81 : RF amp and IF amp
- L77,79,80,82~84,87 : IF amp

IF UNIT (X48-3080-00) (A/5)

- VR4 : Beep tone
- VR5 : Side tone
- VR6 : PROC amp and meter
- VR8,9 : CAR suppression
- VR10 : FM S-meter
- VR11 : SSB squelch
- VR12,13 : S-meter and RX gain
- VR14,15 : AGC
- VR17 : S-meter and RX gain
- L1~4 : RF amp and IF amp
- L5~7 : IF amp
- L8 : PROC amp and meter
- L17 : S-meter and RX gain
- L17~19 : RF amp and IF amp
- L21 : FM gain

TERMINAL FUNCTION

Connector No.	Terminal No.	Terminal Name	Terminal Function
RF UNIT (X44-3120-00)			
CN1	Coaxial	RAT	Reception signal input
CN2	Coaxial	DRV	Drive output
CN3	Coaxial	LO1	1st station transmission input ≅ 0dBm, 73.05-103.5MHz
CN4	Coaxial	LO2	2nd station transmission input ≅ +4dBm, 64.22MHz
CN5	Coaxial	TP1	TG terminal for X1 (73.05MHz MCF) adjustment, 0dBm
CN6	Coaxial	TP2	Spectrum analyzer terminal for X1 (73.05MHz MCF)
CN7	RCA		Cope out (8.83MHz)
CN8	1	14V	14V
	2	NBG	NB gate cut when high
	3	GND	GND
	4	GND	GND
	5	NBI	8.83MHz NB amplifier output
CN9	1	LC2	Relay
	2	LC1	Relay
	3	HC2	Relay
	4	HC1	Relay
	5	CEN2	Relay
	6	CEN1	Relay
	7	GND	GND
	8	NC	
	9	GND	GND
	10	RF1	Relay
	11	RF2	Relay
	12	RIT1	Relay
	13	RIT2	Relay
CN10	1	GND	GND
	2	NB2S	Relay
	3	8A	8V output for analog
	4	NB1S	Relay
	5	NB1V	Relay
	6	NTL	Relay
	7	NV2	Relay
	8	NCH	Relay
	9	-6	-6V output
	10	RITS	Relay
	11	XITS	Relay
	12	NC	
	13	LC1	Relay
	14	HC1	Relay
	15	RIT1	Relay
	16	8A	8V output for analog
	17	NB1V	Relay
	18	FSQ	Relay
	19	SSQ	Relay
	20	NV2	Relay
	21	GND	GND
CN11	1	GND	GND
	2	NC	
	3	ATT2	RF attenuation 12dB, through when 8V, 12dB when low
	4	ATT1	RF attenuation 6dB, through when 8V, 6dB when low
	5	GR	Outputs 12V when 22 to 30MHz BPF selected
	6	AGC	AGC voltage input
	7	FSQ	Relay

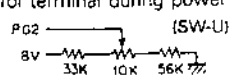
Connector No.	Terminal No.	Terminal Name	Terminal Function
	8	SSQ	Relay
	9	NB2S	Relay
	10	NB1S	Relay
	11	NCH	Relay
	12	-6	-6V input
	13	RF2	Relay
	14	RF1	Relay
	15	45D	} Output for IF unit 455kHz filter selection Active low
	16	45C	
	17	45B	
	18	45A	
	19	PRV	Input terminal for compression meter
	20	CKY	Keying line, radio signal output when high
	21	PP3	 ALC threshold variation terminal during power control
	22	PP2	
	23	PP1	
	24	PG2	Gain control terminal during power control  8V — 33K — [Potentiometer] — 56K — (SW-U)
	25	SS	To CN20 (remote) pin 3
	26	TXB	TXB (8V) input
	27	RXB	RXB (8V) input
	28	8A	8V output for analog
	29	14AF	Relay
	30	DB	When changed over to 8V, forces Q29 on and prevents ALC keying
CN12	1	SPO	Connected to CN20 (remote) pin 1
	2	GND	GND
CN13	1	8D	Relay
	2	14V	Relay
	3	PDE	Power down enable input, RF unit becomes 10W when low
	4	TB0	Relay
	5	TB1	Relay
	6	TB2	Relay
	7	TB3	Relay
CN14	1	GND	Relay
	2	LC2	Relay
	3	HC2	Relay
	4	CEN2	Relay
	5	CEN1	Relay
	6	NTL	Relay
	7	RIT2	Relay
	8	RITS	Relay
	9	XITS	Relay
	10	AIP	AIP control input, open : AIP on, GND : AIP off
	11	TB3	Relay
	12	TB2	Relay
	13	TB1	Relay
	14	TB0	Relay
	15	POE	POE output
	16	8D	Relay
	17	NC	
	18	14V	Relay

TS-850S

TERMINAL FUNCTION

Connector No.	Terminal No.	Terminal Name	Terminal Function
CN15	1	RB2	IC1 : SN74LS145 control input
	2	RBO	IC1 : SN74LS145 control input
	3	RB1	IC1 : SN74LS145 control input
	4	RB3	IC1 : SN74LS145 control input

12pin RB3	13pin RB2	14pin RB1	15pin RBO	Output pin becomes low	Band (MHz)
0	0	1	0	3	~0.5
0	0	0	1	2	0.5~1.62 0.5~1.705 : K type
0	1	0	0	5	1.62~2.5 1.705~2.5 : K type
1	0	0	0	10	2.5~4
1	0	1	0	*	4~7
0	0	0	0	1	7~7.5
0	1	1	1	9	7.5~10.5
1	0	1	1	*	10.5~14
0	0	1	1	4	14~14.5
1	0	0	1	11	14.5~21
0	1	1	0	7	21~22
0	1	0	1	6	22~30

Each BPF is active low

Band of *

5	RBK	RX RF blanking input, when 8V is changed over, NB gate is shut off
6	FEN	IC3 : TC9174 control enable
7	FDA	IC3 : TC9174 control data
8	FCK	IC3 : TC9174 control clock

IC3 output and filter response

3	45D	6	8.83	L74,75	9	45A	
4	8.83	OP1	7	8.83	XF3	10	45B
5	8.83	XF2	8	8.83	OP2	11	45C

9	ALM	ALC meter output
10	CPM	Compression level output
11	VSRM	Reflected wave voltage output
12	VFSM	Forward wave voltage output
13	BPD	Control of power down according to band, active low
14	TPD	Control of power down according to destination, active low
15	ATPD	Power down control during AT tune, active low
16	ATAE	 AT internal/external decision
17	EAT	
18	PT	Final temperature protection output

Connector No.	Terminal No.	Terminal Name	Terminal Function
CN16	1	GND	GND
	2	RL	13V output during TX
	3	14V	13.8V input
	4	PT	Final temperature protection signal input
	5	VSR	Reflected wave detection voltage input
	6	VSF	Forward wave detection voltage input
	7	TXB	TXB (8V) output
	8	8A	8V input
	9	14AF	Relay
CN17	1	MON	TX monitor output, output 95mVrms (no-load) during SSB 100W output (when ALC started)
	2	GND	GND
CN18	Coaxial	MCAR	Monitor carrier input, 8.83MHz ± 1.5kHz, about 0dBm
CN19	Coaxial	TIF	8.83MHz TX IF input, TIF input -13.2dBm when CN2 DRV OUT is 10dBm (f = 14.1MHz)
CN20	1	SPO	CN12 pin 1
	2	C	Relay common terminal
	3	SS	CN11 pin 25
	4	NO	Relay normal open, Closed when TX
	5	NC	Relay normal close, Open when TX
	6	ALC	ALC input
	7	RL	13V output when TX
CN601	1	14V	DV 13V input
	2	NBG	NB blanking pulse output
	3	GND	NBG ground
	4	GND	NBI ground
	5	NBI	NB amplifier signal input
CN602	1	-6V	-6V output
	2	GND	GND
	3	NB1S	
	4	NB2S	
	5	8V	8V input
CN603	1	GND	GND
	2	NBW	NB2 width
	3	FMB	8V when FM mode, otherwise 0V
	4	NFB	8V when FM narrow mode, otherwise 0V
	5	NFMT	0V when FM mode, otherwise 8V
	6	FMD	FM modulation output (to PLL)
	7	GND	GND
	8	GND	GND
	9	FMI	FM modulation input (from IF)

DIGITAL UNIT (X46-308X-XX)

CN1	1	14S	PLL, CAR unit 14V
	2	TU8C	TU-8 control
	3	TXB	Transmission +B
	4	8D	PLL, CAR unit 8V
	5	GND	GND
	6	VB3	VCO select signal
	7	VB2	VCO select signal
	8	VB1	VCO select signal

TERMINAL FUNCTION









Connector No.	Terminal No.	Terminal Name	Terminal Function
	9	VBO	VCO select signal
	10	ULL	Unlock signal
	11	GND	GND
	12	PEL2	PLL, DDS control data enable
	13	PLE1	PLL, DDS control data enable
	14	PCK	PLL, DDS control data clock
	15	PDA	PLL, DDS control data
	16	DLE4	PLL, DDS control data enable
	17	DLE3	PLL, DDS control data enable
	18	DLE2	PLL, DDS control data enable
	19	DLE1	PLL, DDS control data enable
	20	TOC	Repeater tone control
	21	ABSL	DDS register select
	22	GND	GND
	23	CASL	DDS register select
	24	GND	GND
CN2	1	DOT	Dot input
	2	DASH	Dash input
	3	EKS	Electronic keyer select swiwtch
	4	KEY	Key output
	5	TXI	TX inhibit signal
	6	MUP	MIC up switch
	7	MDN	MIC down switch
	8	TXB	Transmission +B
	9	CWC	Mode select signal
	10	RYC	Mode select signal
	11	SSBC	Mode select signal
	12	AMC	Mode select signal
	13	FMC	Mode select signal
	14	ATA	AT AUTO/THROUGH switch
	15	SS	Transmit/receive control signal
	16	ATS	AT start switch
	17	VOX	VOX switch
	18	FULL	FULL/SEMI switch
	19	AIPS	AIP switch
	20	DIM	Dimmer switch
	21	KS1	Electronic keyer speed control
	22	KS2	Electronic keyer speed control
	23	PRS	Processor switch
	24	SM	Signal meter voltage
	25	BEEP	Buzzer output
	26	ABK	AF blanking
	27	RDC	RX DSP select
	28	TDC	TX DSP select
CN3	1	5V	5V
	2	EN1	Main encoder pulse input
	3	EN2	main encoder pulse input
	4	GND	GND
CN4	1	5V	5V
	2	8V	8V
	3	LEN1	LCD control data enable
	4	LEN2	LCD control data enable
	5	LDA	LCD control data
	6	LCK	LCD control data clock
	7	BLK	LCD all light off
	8	INH	LCD all light off
	9	DIM	Dimmer switch
	10	GND	GND
CN5	1	GND	GND
	2	5V	5V
	3	ATL	AT LED control
	4	AIL	AIP LED control
	5	MHL	1MHz LED control

Connector No.	Terminal No.	Terminal Name	Terminal Function
	6	TXL	TX LED control
	7	NTL	Notch LED control
	8	RXAL	Function LED control
	9	RXBL	Function LED control
	10	RXML	Function LED control
	11	TXAL	Function LED control
	12	TXBL	Function LED control
	13	TXML	Function LED control
	14	S0	Key matrix output
	15	S1	Key matrix output
	16	S2	Key matrix output
	17	S3	Key matrix output
	18	S4	Key matrix output
	19	S5	Key matrix output
	20	K5	Key matrix input
	21	K4	Key matrix input
	22	K3	Key matrix input
	23	K2	Key matrix input
	24	K1	Key matrix input
	25	K0	Key matrix input
CN6	1	PT	Temperature protection input
	2	EAT	AT select switch
	3	ATAE	ATA control
	4	ATPD	Power down control
	5	TPD	Power down control
	6	BPD	Power down control
	7	VFSM	RF meter voltage
	8	VSRM	Reflector voltage
	9	CPM	Processor meter voltage
	10	ALM	ALC meter voltage
	11	FCK	Filter select data clock
	12	FDA	Filter select data
	13	FEN	Filter select data enable
	14	RBK	RF blanking
	15	RB3	RX BPF band data
	16	RB1	RX BPF band data
	17	RB0	RX BPF band data
	18	RB2	RX BPF band data
CN7	1	14V	14V
	2	NC	
	3	8V	8V
	4	PDE	Final decision
	5	TB0	TX LPF band data
	6	TB1	TX LPF band data
	7	TB2	TX LPF band data
	8	TB3	TX LPF band data
	9	AIP	AIP control
	10	XITS	XIT switch
	11	RITS	RIT switch
	12	RIT2	RIT/XIT control
	13	NTL	Notch LED
	14	CEN1	Click encoder pulse
	15	CEN2	Click encoder pulse
	16	HC2	Slope tune high cut volume
	17	LC1	Slope tune low cut volume
	18	GND	GND
CN8	1	GND	GND
	2	POD1	AT variable condenser position volume
	3	POD2	AT variable condenser position volume
	4	VRE	5V
	5	PR11	Motor rotate direction control
	6	PR12	Motor rotate direction control
	7	PR21	Motor rotate direction control













TS-850S





TERMINAL FUNCTION

Connector No.	Terminal No.	Terminal Name	Terminal Function
	8	PR22	Motor rotate direction control
	9	APRE	Motor control select
	10	SPED	Motor speed control
	11	ATE	AT connect decision
	12	ATA	AT AUTO/THROUGH
CN9	1	GND	GND
	2	CRW2	CAR point tuned volume
	3	CRV2	CAR point tuned volume
	4	CRL2	CAR point tuned volume
	5	VRE	5V
	6	DPS4	Option filter installed switch
	7	DPS3	Option filter installed switch
	8	DPS2	Option filter installed switch
	9	DPS1	Option filter installed switch
	10	SD	VS-2 control data
	11	SCK	VS-2 control data clock
	12	SBSY	VS-2 busy
	13	STR	VS-2 synthesize control
	14	STBY	DRU-1 stand by control
	15	ACL	DRU-1 reset
	16	WR	DRU-1 write
	17	RD	DRU-1 read
	18	VOB	DRU-1 voice synthesize signal switch
	19	VOA	DRU-1 voice synthesize signal switch
	20	5V	5V
	21	D8	DRU-1 control data
	22	D4	DRU-1 control data
	23	D2	DRU-1 control data
	24	D1	DRU-1 control data
	25	VCK	DRU-1 installed signal
	26	GND	GND
CN10	1	TT	External AT control
	2	TS	External AT control
	3	DGD	Ground
	4	RTS	Personal computer interface
	5	CTS	Personal computer interface
	6	RXD	Personal computer interface
	7	TXD	Personal computer interface
	8	DBC	DSP control input
CN12	1	RMC2	Wired remoto control voltage
	2	DG	Ground
IF UNIT (X48-3080-00)			
CN1	1	NC	
	2	ATA	Antenna tuner AUTO/THROUGH switch, GND when AUTO
	3	SS	Stand by switch, TX when GND
	4	ATS	Antenna tuner start/stop, operation starts upon lowering
	5	GND	GND
	6	NC	
	7	VOX	VOX switch, open at VOX on
	8	FULL	FULL/SEMI switch, GND when FULL
	9	AIPS	AIP switch, operates upon lowering
	10	DIM	Dimmer switch, GND at dimmer on
	11	HIBST	High boost switch, Creates the peak at high pass (about 2.5kHz) of the microphone amplifier
CN2	12	GND	GND
	1	8A	8V for analog
	2	AGO	AGC switch OFF
	3	SLOW	AGC switch SLOW
4	MID	AGC switch MID	

Connector No.	Terminal No.	Terminal Name	Terminal Function
	5	KS1	Speed VR 1 of the built-in electronic keyer 
	6	KS2	Speed VR 2 of the built-in electronic keyer 
	7	CAR2	Carrier volume 2 
	8	GND	GND
	9	NC	
	10	SSBB	8V when SSB
	11	PROS	Speech processor switch, on : 8V (SSB)
	12	MONS	Monitor switch, off : 8V
	13	8A	8V for analog
	14	ATT1	Attenuator switch for 6dB, on : open
	15	ATT2	Attenuator switch for 12dB, on : open
	16	NC	
	17	GND	GND
	18	PRO2	Speech processor gain VR 2 
	19	8A	8V for analog
	20	PG2	Power control gain setting VR 2 
	21	PP1	Power control VR 1 
	22	PP2	Power control VR 2 
	23	PP3	Power control VR 3 
	24	NC	
	25	8A	8V for analog
	26	NB2S	NB2 switch
	27	NB1S	NB1 switch
	28	GND	GND
	29	-6	-6V
CN3	1	DOT	Dot input for built-in electronic keyer
	2	DASH	Dash input for built-in electronic keyer
	3	EKS	Internal/external electronic keyer select
	4	KEY	KEY line
	5	TXI	TX inhibit, inhibit when low
	6	UP	MIC up
	7	DN	MIC down
	8	TXB	8V during transmission
	9	CWC	GND when CW mode
	10	RYC	GND when FSK mode
	11	SSBC	GND when SSB mode
	12	AMC	GND when AM mode
	13	FMC	GND when FM mode
	14	ATA	Antenna tuner AUTO/THROUGH switch, GND when AUTO
	15	SS	Stand by switch, TX when GND
	16	ATS	Antenna tuner start/stop, operation starts upon lowering
17	VOX	VOX switch, open at VOX on	
18	FULL	FULL/SEMI switch, GND when FULL	
19	AIPS	AIP switch, operates upon lowering	
20	DIM	Dimmer switch, GND at dimmer on	
21	KS1	Speed VR 1 of the built-in electronic keyer	
22	KS2	Speed VR 2 of the built-in electronic keyer	
23	PROS	Speech processor switch, on : 8V (SSB)	
24	SM	S-meter voltage output	
25	BEEP	Beep signal input	
26	ABK	RX audio mute signal	

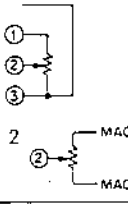
TERMINAL FUNCTION

Connector No.	Terminal No.	Terminal Name	Terminal Function
	27	RDC	Low when DSP reception is connected
	28	TDC	Low when DSP transmission is connected
CN4	1	GND	GND
	2	NC	
	3	ATT2	Attenuator switch for 12dB, on : open
	4	ATT1	Attenuator switch for 6dB, on : open
	5	28GD	28MHz gain down signal, high when 28MHz
	6	AGC	AGC line
	7	FSQ	FM squelch setting voltage
	8	SSQ	FM squelch setting voltage
	9	NB2S	NB2 switch
	10	NB1S	NB1 switch
	11	NCH	Notch setting voltage
	12	-6	-6V
	13	RF2	RF gain VR 2 
	14	RF1	RF gain VR 1 
	15	45D	12kHz filter select signal
	16	45C	6kHz filter select signal
	17	45B	2.7kHz filter select signal
	18	45A	Option CW filter select signal
	19	PRV	Compression meter voltage
	20	CKY	Keying signal
	21	PP3	Power control VR 3 
	22	PP2	Power control VR 2 
	23	PP1	Power control VR 1 
	24	PG2	Power control gain setting VR 2 
	25	SS	Stand by switch, TX when GND
	26	TXB	8V during transmission
	27	RXB	8V during reception
	28	8A	8V for analog
	29	14AF	13.8V for audio amplifier
	30	TDB	8V when TDC is low
CN5	Coaxial	RIF	RX IF input (8.83MHz)
CN6	Coaxial	RIF	TX IF output (8.83MHz)
CN7	Coaxial	LO3	Local 3 input (8.375MHz)
CN8	1	DTIF	DSP transmission input
	2	GND	GND
CN9	1	CAR	Carrier input
	2	GND	GND
CN10	1	DRIF	DSP reception output
	2	GND	GND
CN11	1	AV1	AF VR 1 
	2	AV2	AF VR 2 
	3	GND	AF VR 3 
	4	NC	
CN12	1	SPO	Speaker output for remote jack
	2	GND	GND
CN13	1	PH1	Phone jack output
	2	PH2	Phone jack through
	3	GND	GND
CN14	1	GND	GND
	2	SP	Internal speaker output
CN15	1	STON	Side-tone input
	2	GND	GND
CN16	1	MON1	Monitor detection input
	2	GND	GND
CN17	1	MON1	Monitor VR 1 
	2	GND	Monitor VR 3 
	3	MON2	Monitor VR 2 

Connector No.	Terminal No.	Terminal Name	Terminal Function
CN18	1	NC	
	2	DRU10	DRU-1 monitor input
	3	GND	GND
	4	VS2	VS-2 input
	5	NC	
CN19	1	GND	GND
	2	DAF2	RX AF input for DSP
	3	GND	GND
	4	DAF1	RX AF output for DSP
	5	CKY	CKY for DSP
	6	TXB	TXB for DSP
	7	MAG	MIC amplifier GND for DSP
	8	MAO	MIC amplifier output for DSP
CN20	1	MAG	MIC amplifier ground 
	2	MAO	MIC amplifier output
	3	MV2	MIC gain VR 2 
	4	MVG	MIC gain VR 3 
	5	PV2	Processor processor VR 2 
	6	NC	
CN21	1	GND	GND
	2	VI	Input/output for DRU-1
CN22	1	MIC	MIC connector
	2	MICG	GND for MIC
	3	8M	8V output for MIC connector
	4	SS	Stand by switch for MIC
	5	UP	Up switch for MIC
	6	DN	Down switch for MIC
CN23	1	FMN	FM narrow signal
	2	MUTE	"H" except when FM transmission
	3	FMB	8V when FM mode
	4	MAG	FM MIC amplifier GND
	5	MAO	FM MIC amplifier output
J1	1	NC	
	2	NC	
	3	ANO	RX audio output
	4	ANG	RX audio output GND
	5	PSQ	GND when squelch open, open when squelch closed
	6	SM	S-meter voltage output
	7	NC	
	8	GND	GND
	9	PKS	Stand by switch when ANI input used
	10	NC	
	11	ANI	TX input
	12	ANIG	TX input GND
	13	SS	Stand by switch
J2		EXT. SP	External speaker jack
J3		KEY	Key jack
PLL UNIT (X50-3130-00)			
CN1		DLO1	DDS1 output, 4.45~4.95MHz, -17dBm
CN2		20M	Reference signal output for CAR unit, 20MHz, -6dBm
CN3	1	TXB	Transmission +B
	2	8D	8V
	3	GND	GND
	4	PCK	DDS data clock
	5	PDA	DDS data
	6	DLE4	DDS enable, IC3

TS-850S

TERMINAL FUNCTION

Connector No.	Terminal No.	Terminal Name	Terminal Function
	7	DLE3	DDS enable, IC2
	8	DLE2	DDS enable, IC4
	9	DLE1	DDS enable, IC1
	10	TOC	Sub-tone ON/OFF control
	11	ABSL	DDS data select, IC1 and IC3
	12	CASL	DDS data select, IC2 and IC4
CN4	1	14S	Power line, 10~14V
	2	TU8C	TU-8 control line, active low
	3	TXB	TXB
	4	8D	8V for digital
	5	GND	GND
	6	VB3	VCO select line, } 21.5~30MHz 14.5~21.49999 active high } 7.5~14.49999 30kHz~7.49999
	7	VB2	
	8	VB1	
	9	VB0	
	10	UNL	Unlock detection output
	11	GND	GND
	12	PLE2	PLL2 (VCO2, LO2) enable
	13	PLE1	PLL1 (LO1) enable
	14	PCK	PLL clock
	15	PDA	PLL data
	16	DLE4	DDS enable
	17	DLE3	DDS enable
	18	DLE2	DDS enable
	19	DLE1	DDS enable
	20	TOC	Sub-tone ON/OFF control
	21	ABSL	DDS data select, IC1 and IC3
	22	GND	GND
	23	CASL	DDS data select, IC2 and IC4
	24	GND	GND
CN5		LO1	LO1 output, 73.08~103.05MHz, 0dBm
CN6		LO2	LO2 output, 64.2200MHz, 5dBm
CN7	1	GND	GND
	2	TON	Option TU-8 AF output
	3	TOB	Option TU-8 power supply
CN8	1	GND	GND
	2	FMD	FM modulation input
CN9	1	GND	GND
	2	10K	External DSP reference signal 10kHz, 200mVp-p (600Ω)
CAR UNIT (X50-3140-00)			
CN1	1	TXB	Transmission power +8
	2	8D	8V
	3	GND	GND
	4	PCK	DDS data clock
	5	PDA	DDS data
	6	DLE4	DDS enable, IC3
	7	DLE3	DDS enable, IC2
	8	DLE2	DDS enable, IC4
	9	DLE1	DDS enable, IC1
	10	TOC	Sub-tone ON/OFF control
	11	ABSL	DDS data select, IC1 and IC3
	12	CASL	DDS data select, IC2 and IC4
CN2		DLO1	Main local : 1Hz step
CN3		20M	Reference 20MHz input
CN4		LO3	Local : 8.375MHz
CN5		MCAR	Monitor carrier : 8.83MHz
CN6	1	CAR	Carrier : 455kHz
	2	GND	GND
	3	GND	GND
	4	RTK	RTTY keyer input

Connector No.	Terminal No.	Terminal Name	Terminal Function
CN7		CTON	Tone for CW side-tone
FILTER UNIT (X51-3100-00)			
CN1		PO	Filter input
CN2		ATI	AT input
CN3	1	8V	+8V
	2	GND	GND
	3	GND	GND
	4	14S	+14V
	5	14S	+14V
	6	LP0	Filter selection 4-digit BCD
	7	LP1	Filter selection 4-digit BCD
	8	LP2	Filter selection 4-digit BCD
	9	LP3	Filter selection 4-digit BCD
	10	RL	+14V during transmission
	11	VSF	Forward wave detection
	12	VSR	Reflected wave detection
CN4	1	GND	GND
	2	14S	+14V
	3	GND	GND
	4	10A	7.5~10.5MHz
	5	28A	24.5~30MHz
	6	25A	21.5~24.5MHz
	7	7A	4~7.5MHz
	8	21A	18.5~21.5MHz
	9	18A	14.5~18.5MHz
	10	4A	2.5~4.0MHz
	11	14A	10.5~14.5MHz
			} AT coil tap band data
CN5		AT2	AT output
CN6		RAT	Reception antenna
CN7	1	GND	GND
	2	RL	+14V during transmission
	3	14S	+14V
CN8	1	TT	Tuning control
	2	TS	Tuning control
CN9	1	DBC	DSP connection
	2	GND	GND
	3	DGO	Digital GND
	4	TXD	TX data output
	5	RXD	RX data input
	6	GND	GND
	7	CTS	Transmittable input
	8	RTS	TX request output
	9	GND	GND
	10	GND	GND
	11	TS	Tuning control
	12	TT	Tuning control
CN10	1	TXB	+12V during transmission
	2	DAF1	DSP audio output
	3	GND	GND
	4	CKY	Keying control
	5	DAF2	DSP audio input
	6	GND	GND
	7	MAG	MIC amplifier GND
	8	MAO	MIC amplifier output
CN11	1	10K	10kHz output
	2	GND	GND
CN12		RTK	RTTY keying
CN13		CAL	Calibration input
CN14		TP1	VSR voltage detection

TERMINAL FUNCTION

Connector No.	Terminal No.	Terminal Name	Terminal Function
CN15	1	RMC	Remote control signal
	2	DG	GND
	3	GND	GND
W1	1	14S	+14V
	2	RL	+14V during transmission
	3	GND	GND
J1	1	DAF1	DSP audio output
	2	GND	GND
	3	DAF2	DSP audio input
	4	GND	GND
	5	DBC	DSP connection
	6	RTK	RTTY keying
	7	CKY	Keying control
	8	GND	GND
	9	GND	GND
	10	10K	10kHz output
	11	MAO	MIC amplifier output
	12	MAG	MIC amplifier GND
	13	TXB	+12V during transmission
J2	1	DGD	Digital GDN
	2	TXD	TX data output
	3	RXD	RX data input
	4	CTS	Transmittable input
	5	RTS	TX request output
	6	NC	
J3		RMC	Remote control

Connector No.	Terminal No.	Terminal Name	Terminal Function
AT UNIT (X53-3340-00)			
CN1		AT1	AT input
CN2		AT2	AT output
CN3	1	VRE	+5V reference for A/D
	2	POD2	VC2 position detection, VR101 output
	3	GND	GND
	4	POD1	VC1 position detection, VR102 output
CN4	1	NC	
	2	M2-	Motor 2 drive -
	3	M2+	Motor 2 drive +
	4	M1-	Motor 1 drive -
	5	M1+	Motor 1 drive +
CN5	1	NC	
	2	F15	Power line, 11-14V
	3	GND	GND
CN6	1	ATA	Make for AT through/on relay, on when low
	2	NC	
CN7	1	ATG	GND for discriminating that AT is connected to microcomputer
	2	SPED	Motor speed control pulse
	3	APRE	Control selection, high : preset type, low : auto tuning
	4	VRE	+5V reference for A/D
	5	PR22	Motor 2 control signal
	6	PR21	Motor 2 control signal
	7	POD2	VC2 position detection
	8	PR12	Motor 1 control signal
	9	PR11	Motor 1 control signal
	10	POD1	VC1 position detection
	11	GND	GND